

WALLBOX

Assembly manual

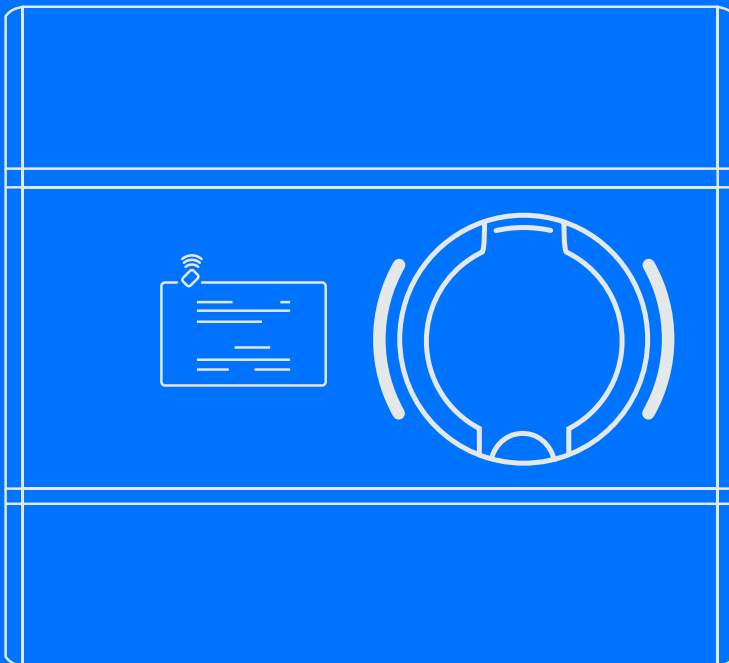

Copyright Enelion sp. z o.o.
The manual may change as the product develops.
All rights reserved.
Document version: V 6.1
Number of pages: 24.
Release date: 29.02.2024

Contents

1. Important information.	3
1.1. General provisions	3
1.2. Safety Guidelines	4
2. General informations	5
2.1. Opening and closing ENELION WALLBOX	5
3. Design indications of the installation	8
3.1. Power Supply Network Systems	8
3.2. RCD B with automatic reclosing device	9
3.3. Recommended power connection	10
3.4. Recommended communication network	11
3.5. Location selection criteria	11
4. Assembly	12
4.1. Preparing the installation	12
4.2. Selection of bolts and anchors	12
4.3. Cable routes	13
4.4. Mounting the device	14
5. Connection	15
5.1. Power connection	15
5.1.1. Standard power connection	16
5.1.2. Power connection in version with MID meter	17
5.1.3. RCMB Connection	18
5.2. ENELION Chain	18
5.3. Internet connections via Ethernet interface in LAN network	21
6. Maintenance	22
6.1. Cleaning	22
6.2. Repair	22
7. Technical data	23
7.1. ENELION WALLBOX	23

Congratulations on the purchase of the ENELION charger and thank you for your trust.
Before the installation, make sure that the module packages contain all the elements. Current version of the operation manual can be accessed at: <https://enelion.com/en/support/>

See the contents of the manual before initiating any activities related to the installation or the activation of the charger.

1. Important information.

1.1. General provisions

The ENELION charger (here in after referred to as the device, charger, or charging terminal) is a charging station designed for electric vehicle charging within the meaning of the 'Act on Electromobility and Alternative Fuels' dated January 11, 2018, in paragraphs 5, 12, 13, and 27 of Article 2 of the aforementioned act.

The installation and servicing of the device must be carried out by qualified and authorized individuals, and repairs may only be performed by the manufacturer or entities authorized by the manufacturer. During the warranty period, only authorized service centers and the manufacturer are allowed to perform warranty repairs.

Interference with mechanical, electrical, and electronic components, as well as the device's software, is strictly prohibited and may void the warranty. Exceptions are actions described in the following instruction manual or those agreed upon in writing with the manufacturer.

The manufacturer is not responsible for property damage resulting from prohibited interference with the product.

The electrical installation to be used during device operation must meet the conditions described in the installation manual. The manufacturer is not responsible for incorrect execution and/or protection of the electrical installation to which the device is connected.

The manufacturer is not responsible for the improper functioning of the electrical installation to which the device is connected.

The electrical installation to be used during device operation must comply with the legal standards applicable at the installation and operation location of the device.

The manufacturer is not responsible for damages caused by an electrical installation that does not comply with legal standards.

The device does not have a built-in power switch.

The device is activated when the power supply voltage is applied. Power disconnection must be ensured by appropriate devices in the electrical installation described in the installation manual. Except in emergency situations, the device should not be switched

off during the charging process.

It is prohibited to power on the device when the device housing is open.

It is prohibited to use a charger that is mechanically damaged or indicates a critical error.

Objects not intended for this purpose must not be placed in the charger socket. The only object intended for insertion into the charger socket is a functional power cable with the appropriate power and type for the electric vehicle, terminated with a functional type 2 plug according to EC 621962.

The use of extension cords, adapters, and charging cable extensions is prohibited.

The manufacturer is not responsible for loss of health or life resulting from non-compliance with the above recommendations.

During the warranty period, the manufacturer allows the purchase of support packages for the device (extended warranty/service) subject to a qualifying review before purchasing the package. Details can be obtained from the ENELION sales department.

The charging station does not support ventilation functions.

The nameplate present on the device is an integral part of it and must not be removed or damaged, as this may result in the loss of the manufacturer's warranty.

INFO

Three self-adhesive labels with information about the current value have been included in the set. Choose the appropriate one according to the specifications and affix it next to the nameplate.



Fig. 1: Example of info plate

1.2. Safety Guidelines

Do not carry out external installation during atmospheric precipitation or strong winds if there is a risk of water or contaminants entering the device.

All actions described in this manual should be performed after ensuring that there is no voltage in the power cable.

If any damage to components such as the socket, charging cable, plug, plug holder, or any other fixed/permanent component is observed, it should be reported to the charging station operator.

2. General informations

The WALLBOX is a charging station designed for electric-powered, roadworthy, personal vehicles. It is constructed with an aluminum housing enclosed by reinforced polymer sides. It includes a charging process control module, a front panel with an RFID reader, an OLED screen, and LED signaling, as well as a Type 2 socket. Additional accessories can be mounted, and the device's functionality can be expanded by adding accessories such as ENELION Bridge, ENELION MID, or ENELION RCM B protection. Some parameters and functions can be modified by reprogramming the device using the included RFID card. The ENELION WALLBOX is available in two colors: black and silver.



Fig. 2: ENELION WALLBOX in black.

All ENELION charging stations are compatible with the proprietary ENELION Chain communication protocol, enabling operation within a local network of chargers. This allows activating the ENELION DLB function, providing dynamic load balancing. This feature reduces the number of devices requiring an internet connection and allows for more efficient utilization of power for vehicle charging.

All ENELION devices can be equipped with the ENELION Bridge (available as a separate add-on). It adds smart functions to the devices and enables connection to a remote management system (compatible with OCPP 1.6) via the internet.

INFO

To learn more, please refer to the „User Manual.“ It contains detailed information about the functionality and operation of the device.

2.1. Opening and closing ENELION WALLBOX

INFO

The 3 mm Allen key is needed to open (or close) the ENELION WALLBOX. No other tool is necessary for this operation..

INFO

Closing of the device is performed by repeating the steps in the reverse order.

INFO

The operations described below are identical for the device already mounted on the wall. Please note that the device must be opened at least once before the installation to allow access to the mounting holes on its back and to connect the power cable.

1. Remove the rubber plugs from the top left and right hole of the device.
2. Insert the supplied Allen key into the exposed hole. The key should be inserted until resistance is felt, i.e. until it cannot be pushed deeper.

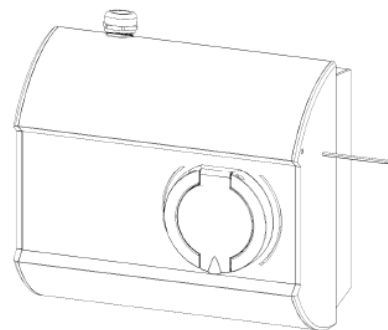

Fig. 3: Inserting an Allen key.

3. Turn the key counterclockwise until the locking pin is aligned with the side of the charger. Remove the Allen key from the hole. Repeat action number 2 for the second locking pin.

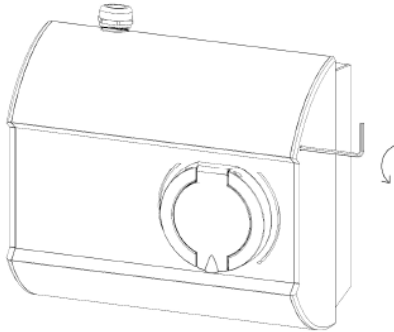

Fig. 4: Unscrewing the locking pin.

4. Slide the front panel upwards of the device by holding the socket housing use a suction cup as an option until the lower edge of the front panel is exposed.

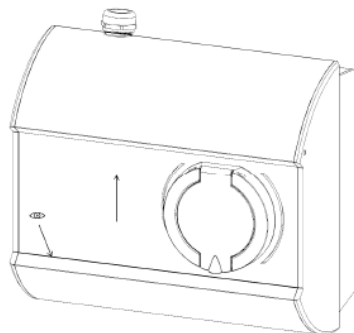

Fig. 5: Front panel moved upwards.

5. Holding the socket housing, pull the bottom edge of the panel until it is released from the housing and tilted slightly.

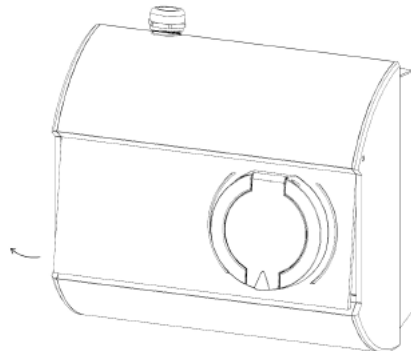

Fig. 6: Front panel slightly tilted.

6. Holding the front panel in the same plane, slide it downwards from the top frame of the device.

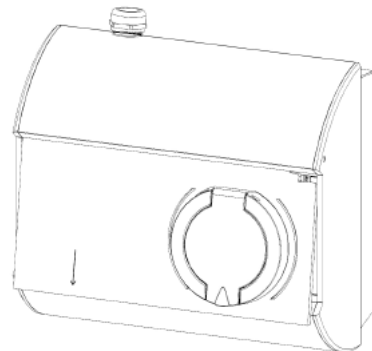

Fig. 7: Removing the front panel from the device housing.

7. Slowly continue to pull out the front panel, watchful of the socket lock not hooking onto the housing.-

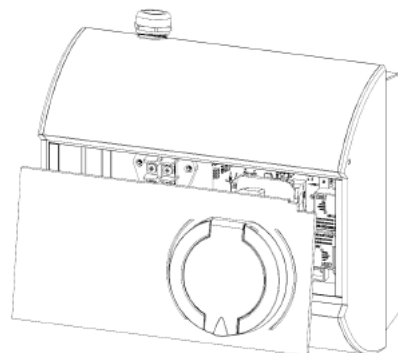

Fig. 8: Pulling out the front panel.

8. The front panel may freely rest next to the housing, hanging within the reach of the socket connection wires.

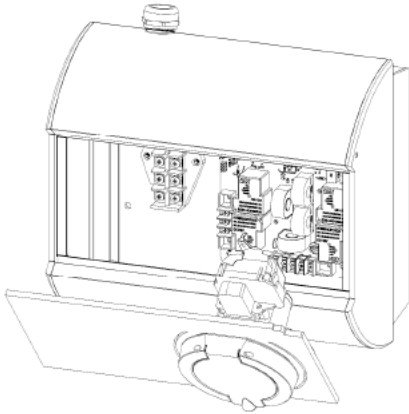

Fig. 9: The device open with the access to its interior.

INFO

The panel is fitted into place by following the above operations in the reverse order.

WARNING

Be careful not to crumple the signal tape while fitting the front panel..

3. Design indications of the installation

3.1. Power Supply Network Systems

ENELION charging stations are designed for five-wire power supply. In a TN-S 230/400V network, this is the standard option.

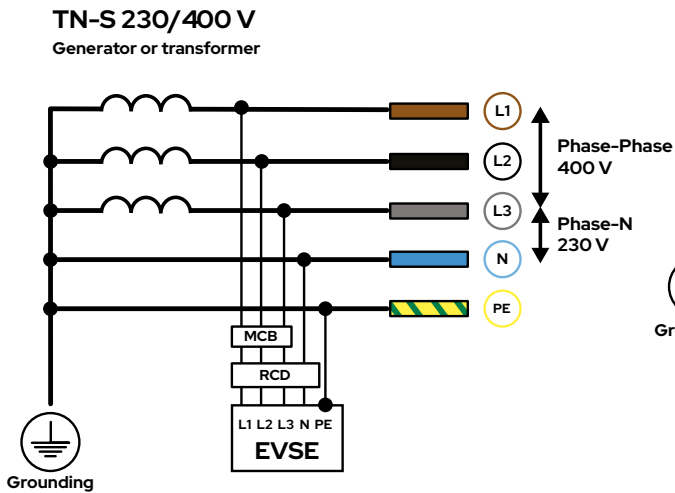

It is possible to power the station from other network systems described below:

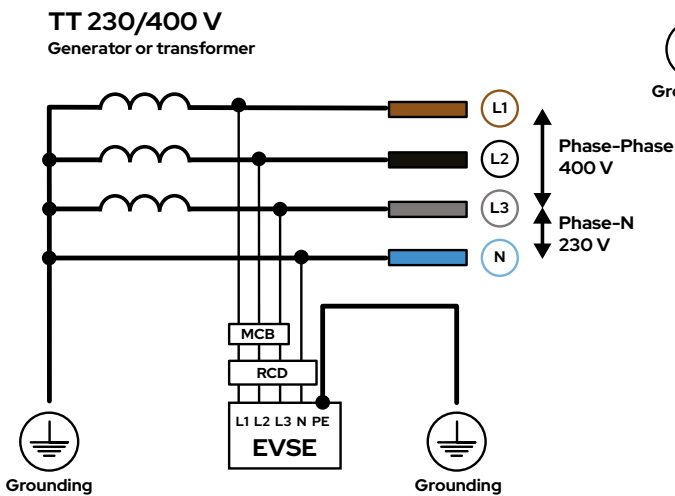

In the TN-C system configuration, you should separate the PEN conductor into N and PE as shown in the diagram below.

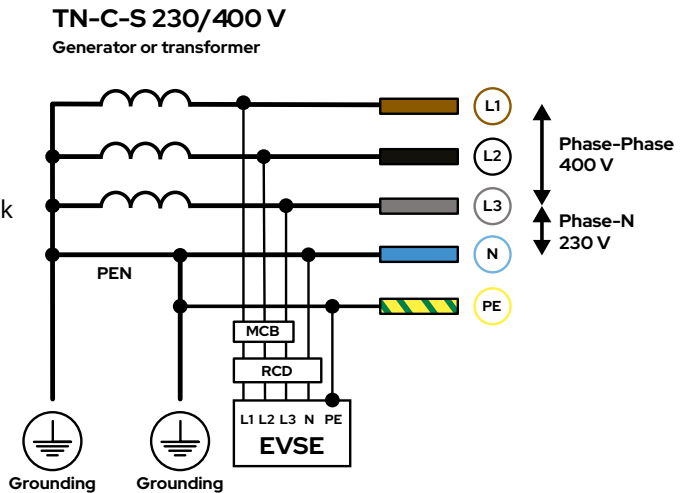
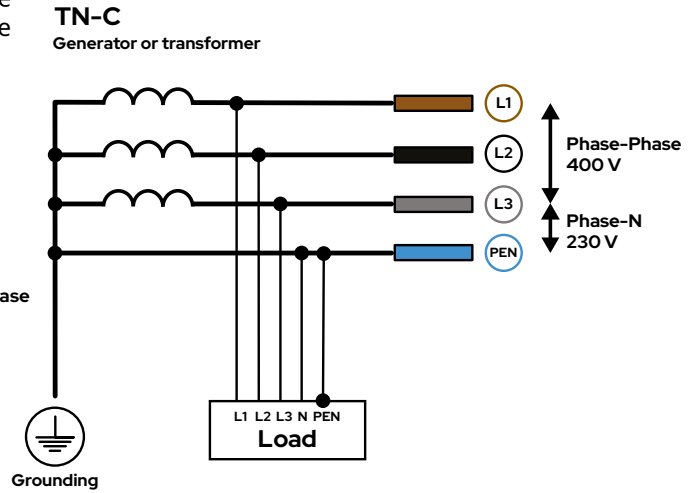

In the case of an IT 120/230 V network, commonly found in Norway for example, the connection looks as follows. It's important to note that one of the phases serves as the Neutral wire; this is crucial during the installation of the RCD. In such a network, three-phase charging is not possible; only some vehicles will be able to charge using a two-phase system.

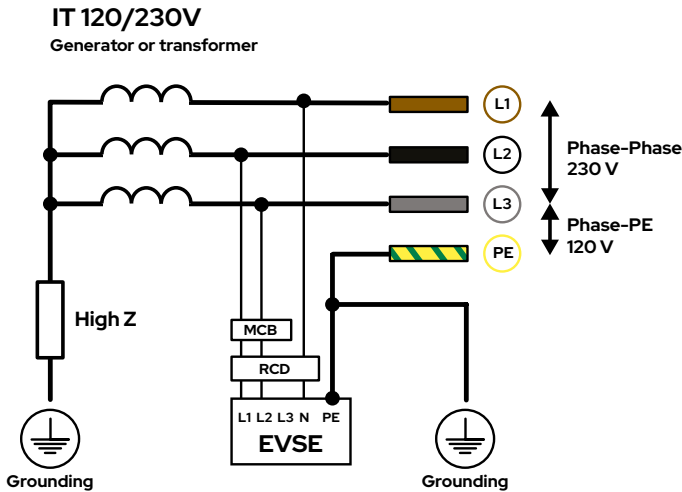

It is not possible to power the station from an IT 230/400 V network.

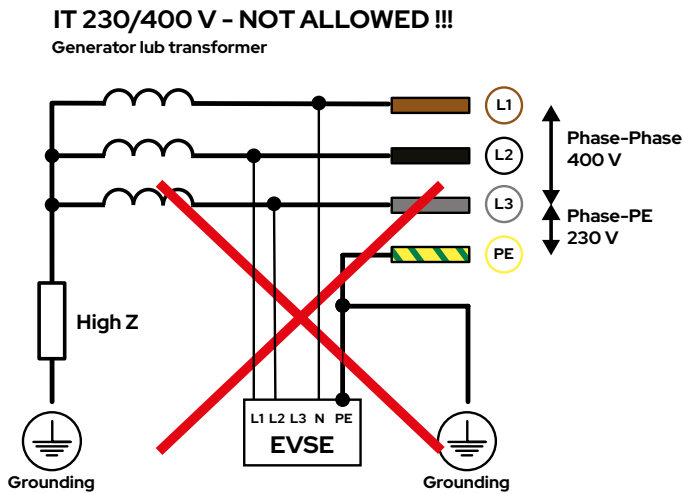

Other, more complex power supply systems require technical consultations before purchase.

3.2. RCD B with automatic reclosing device

There is an option to install an RCD B circuit breaker with an automatic reclosing device. The automatic reclosing device is a separate physical device mounted on a DIN rail and must be installed next to the circuit breaker. Depending on the number of phases, the circuit breaker with an automatic reclosing device occupies 4 or 5 positions on the DIN rail.

The power supply to the automatic reclosing device should be connected before the power supply to the RCD B to prevent it from being switched off when the RCD B activates.

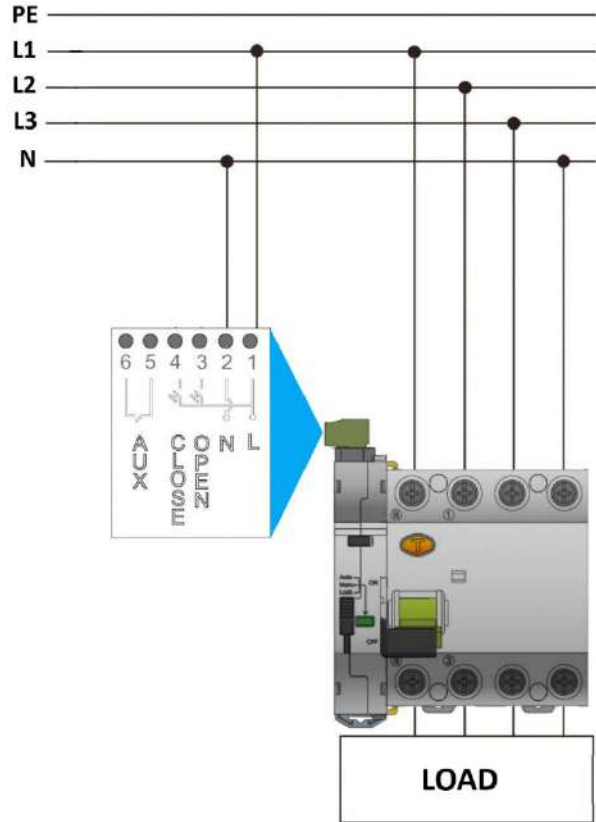

Fig. 10: Instructions for connecting RCD B with an automatic reclosing device to the power supply.

The automatic reclosing device is equipped with an LED interface that indicates its status:

1. Continuous green means the device is ready to operate.
2. Continuous red indicates device lockout after 3 unsuccessful lift attempts. In this case, the presence at the station is required, and the automatic reclosing device must be raised manually.
3. Flashing red indicates that the automatic reclosing device is attempting to lift the differential current switch lever.

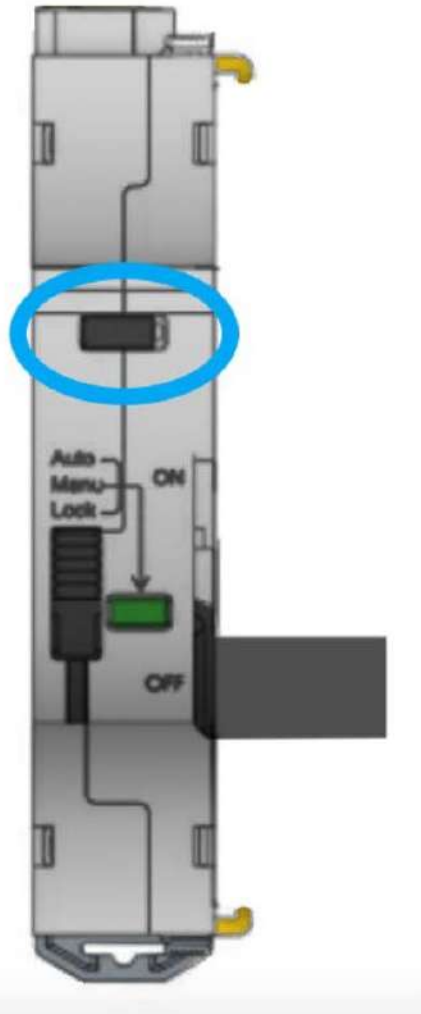

Fig. 11: Automatic reclosing device Interface

The automatic reclosing device can operate **in three modes:**

Auto mode: In this mode, the automatic reclosing device attempts to lift the RCD a maximum of 3 times in case the differential current switch is tripped.

1. The first attempt is made 10 seconds after the differential current switch is tripped.
2. If the switch is tripped again within 15 minutes, the automatic reclosing device will make a second attempt after 1 minute.
3. If the switch is tripped again within a time frame of less than 15 minutes, the third lift attempt will be made after 5 minutes.

The fourth trigger of the differential current switch deactivates the automatic reclosing device. At this point, manual lifting of the RCD B switch lever is required.

The process has been presented in the form of a diagram in the illustration below.

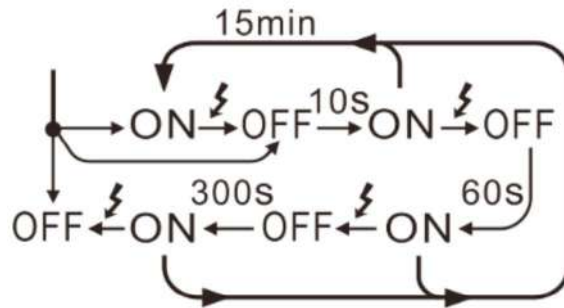

Manual mode: Standard operation of the differential current switch. After tripping, RCD B requires manual lifting.

Lock mode: Protection against unauthorized access. When the automatic reclosing device is set to this mode, a seal can be applied to prevent unauthorized individuals from changing the automatic reclosing device’s operating mode.

When purchasing an ENELION station with a differential current switch with an automatic reclosing device, the automatic reclosing device will be set to auto mode.”

3.3. Recommended power connection

ENELION charging stations are adapted to five-wire power supply from TN-S type and TT type grid. It is possible to apply three-wire power supply from TN-S type grid.

⚠ WARNING

Connection possibilities have been described in “User manual”, in the Device configuration section.

ENELION charging terminal must be powered from the electrical switchboard. The board must have the required protections in the form of an overcurrent circuit breaker with BorC characteristics and rated current of 32 A or lower, appropriate to the device version. To be compliant with the PN-EN IEC 61851-1: 2019-10 standard, each charging point must also be protected against type A or B residual current. This requirement must be met by one of the below:

1. Installation of a type B residual current device (RCD B 30 mA/40 A) or RCD EV (30 mA/40 A) in the switchboard,
2. Installation of a type A residual current device (RCDA 30 mA/40 A) in the switchboard with the application of ENELION RCM B – type B Residual Current Monitor, attached to the charging terminal.

The final selection of the safety devices belongs to an authorized designer or a qualified electrician.

The above requirements result in the necessity to use independent cables for multi-socket devices: WALLBOX DUO POWER and WALLBOX Adspace.

WALLBOX Duo multi-socket device allows one to power the charging sockets only in 1-phase mode. Therefore, it should be powered with one four-wire cable.

The cross-section of the power supply cables must be selected by an authorized electrician, depending on the distance from the switchboard and other conditions pertinent to the location. To obtain the maximum charging power in wall-mounted devices, the use of cables with a conductor cross-section not greater than 6 mm² is recommended. **The diameter of the power supply cable with insulation must not exceed 16 mm.**

Cables running underground must be installed in accordance with the binding building regulations. For convenient installation, flexible power cables, stranded type, terminated with clamping sleeves are recommended

INFO

In case of single phase installation, the maximum cross-section of the power supply cable to be assembled in connection terminals is 10 mm². The diameter of the power supply cable with insulation must not exceed 16 mm.

WARNING

To supply the voltage to the installed and connected charging station, first switch on the RCD protection, and next the overcurrent switch.

For installation, about 50 cm of power cable reserve from the expected installation position is recommended. For WALLBOX Adspace devices, a reserve of about 110 cm of the cable supplying power to the left socket is recommended.

3.4. Recommended communication network

ENELION devices support the ENELION Chain communication interface. For its implementation, a wired connection between the devices is required using an Ethernet CAT 5 or CAT6 cable.

For installation, leave about 50 cm of communication cables from the expected installation position.

The network works in a serial topology where:

- the number of ENELION charging points does not exceed 100 devices,
- the total length of the communication cable connecting the devices does not exceed 500 m.



Fig. 12: ENELION Chain network topology.

ENELION devices equipped with the ENELION Bridge module can use the Internet connection via the Ethernet interface in the LAN network. In order to utilize this function, run the Ethernet CAT 6 cable to the device in which the use of this option is expected.

INFO

Devices equipped with ENELION Bridge can also use WiFi and GSM interfaces to ensure the Internet connection, but they do not have requirements related to cable installation.

3.5. Location selection criteria

Wall-mounted ENELION devices may be installed both internally or externally.

The device has been designed to be installed near parking spaces for electric vehicles. When used in the vehicle collision hazard zone, the structure should be secured with appropriate fenders painted in yellow and black stripes (warning about the gauge).

Bear in mind that the national regulations may define the space for the installation. The device should not be located in a place of high exposure to sunlight, which could cause overheating. Do not install the device near

heat sources or in small, closed spaces (e.g. in a box).

It is forbidden to install power cord that does not comply with the guidelines in section 3.1 Recommended power connection. It is forbidden to install the device in potentially explosive environment.

Local regulations for electrical installations, fire prevention measures and accident prevention must be taken into account, and escape routes at the installation site must be provided.

It is forbidden to install the device in a location where falling objects may damage the charger.

Before installation, make sure that the mounting space for the device is sufficient.

WALLBOX family devices should have at least:

1. 10 cm clearance on each side of the unit.

For devices from the Stilo family, it is necessary to provide at least:

1. 10 cm clearance on the right side of the unit.
2. 50 cm clearance above the top edge of the device.
3. 100 cm clearance below the bottom edge of the device.

⚠ WARNING

The manufacturer accepts no responsibility for any damage resulting from failure to comply with the above-mentioned recommendations.

4. Assembly

⚠ WARNING

Before commencing the installation, switch off the power supplied to the cables.

4.1. Preparing the installation

1. Place the packaged ENELION WALLBOX horizontally, in accordance with the markings on the packaging. Cut the package open along the indicated line. Take the device out of the cardboard box, remove the polystyrene protective casing and put the device in the safe position.
2. The polystyrene protection contains useful accessories necessary for the mounting of the device. Before recycling the packaging, collect those accessories that include:
 - cable gland plug,
 - RFID configuration card and RFID pendant.
3. Open ENELION WALLBOX DUO POWER in accordance with the instruction included in section 2.1 Opening and closing ENELION WALLBOX DUO POWER.

4.2. Selection of bolts and anchors

ENELION WALLBOX DUO POWER is mounted on vertical surface using bolts. The device has four mounting openings. Additionally, the device is equipped with holds facilitating the assembly.

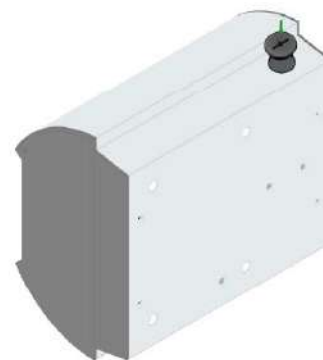

Fig. 13: Locations of cable entry points in ENELION WALLBOX.

1. four mounting holes are positioned on the plan of a rectangle with dimensions of 230 mmx 96 mm (width x height),
2. mounting holes have a diameter of 5,5 mm,
3. the device weighs between 3 kg – 3,5 kg,
4. mounting must provide stability for the device to withstand significant forces affecting it when plug-ging and unplugging the charging cable in the socket.

⚠ WARNING

Use all mounting holes in the process of installation. Failure to do so will result in the loss of water and dust resistance of the device, classified, as a default, as IP 54. This can lead to damage or failure of the charger, and consequently to loss of life or health. The manufacturer is not responsible for damage and injuries arising from failure to observe the above recommendations.

4.3. Cable routes

The default power cable entry is at the top of the device. It is possible to insert the power cable from the bottom of the device by moving the gland by oneself. To do this, remove the plug on the bottom of the device.

The insertion of communication cables is possible from the bottom of the device. This requires the removal of the plug and the installation of a gland suitable for the type and number of communication cables to be routed. The opening diameter for the communication cable gland is 19 mm.

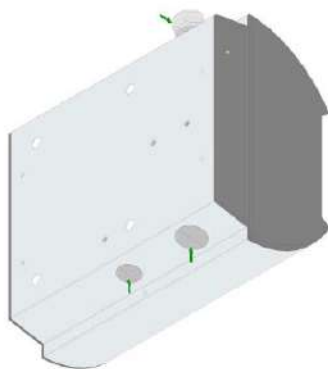

Fig. 14: Locations of cable entry points in ENELION WALLBOX.

The removal of plugs for the assembly of cable glands should be performed according to the following guidelines:

1. place the device on a stable surface,
2. use a hammer and a flat-bladed screwdriver to knock out the gland hole plug carefully.

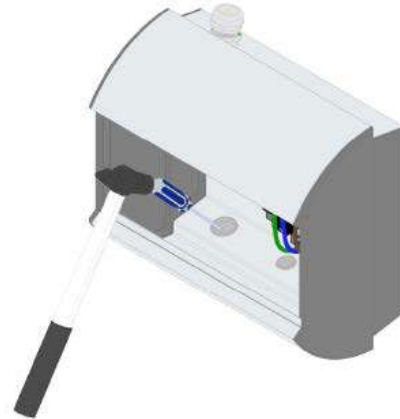

Fig. 15: Removing the plugs for cable entry openings..

The cable gland in the upper part of the device should be put into the hole in the lower part of the device and screwed to ensure tightness. The gland nut requires a 32 mm spanner and the gland requires a 30 mm spanner. After repositioning the gland, the opening in the upper part of the device should be closed with the additional plug provided with the product.



Fig. 16: Additional plug with a nut provided with the product.



Fig. 17: Mounting place for the additional plug.



Fig. 18: Mounting method for the additional plug.

The cable gland for communication cables should be installed in accordance with the manufacturer's instructions.

ⓘ WARNING

To make sure the device is water-tight in accordance with IP54 class and keep the manufacturer's warranty for the device, after relocating the cable gland from the top to the bottom of the device, the unused hole must be secured with a plug and a nut set included with the device.

4.4. Mounting the device

ⓘ INFO

The device has been equipped with a template facilitating the installation

1. Determine the final location of the device using the attached template and the level, and mark the mounting holes. The template marks the mounting holes, the outline of the rear wall of the device, the axis of the glands (both in the version with a gland in the upper and the lower part of the device) and the optimal cable lengths. Mounting holes should be at least 5 cm from the edge of the wall (in case of a recess, minimum 20 cm—to leave enough space for the use of Allen key). The axis of the power cable must coincide with the axis of the glands marked on the template. Make sure that the power cord is at least 350 mm long, measured from the edge of the device marked on the template.
2. Make assembly holes and install expansion bolts. Mounting holes should be made in accordance with the specification of expansion bolts, which should be placed in the cleaned holes.
3. Make sure that there is no voltage in the power cords.

4. Open the device as described in section 2.1 Opening and closing ENELION WALLBOX.
5. Put the device in the target position by threading the power cable through the glands.
6. Fasten the device with screws using a screwdriver with a shaft length of at least 150 mm.
7. Screw on the power cable gland ensuring tightness.
8. (Optional) Insert at least 350 mm of the communication cables into the device.

The device mounted in this way can be connected.

5.Connection

5.1. Power connection

ENELION WALLBOX comes in various types. Depending on which type is being installed, the power supply cables may be connected

directly to the terminals or to the approved integrated MID meter.

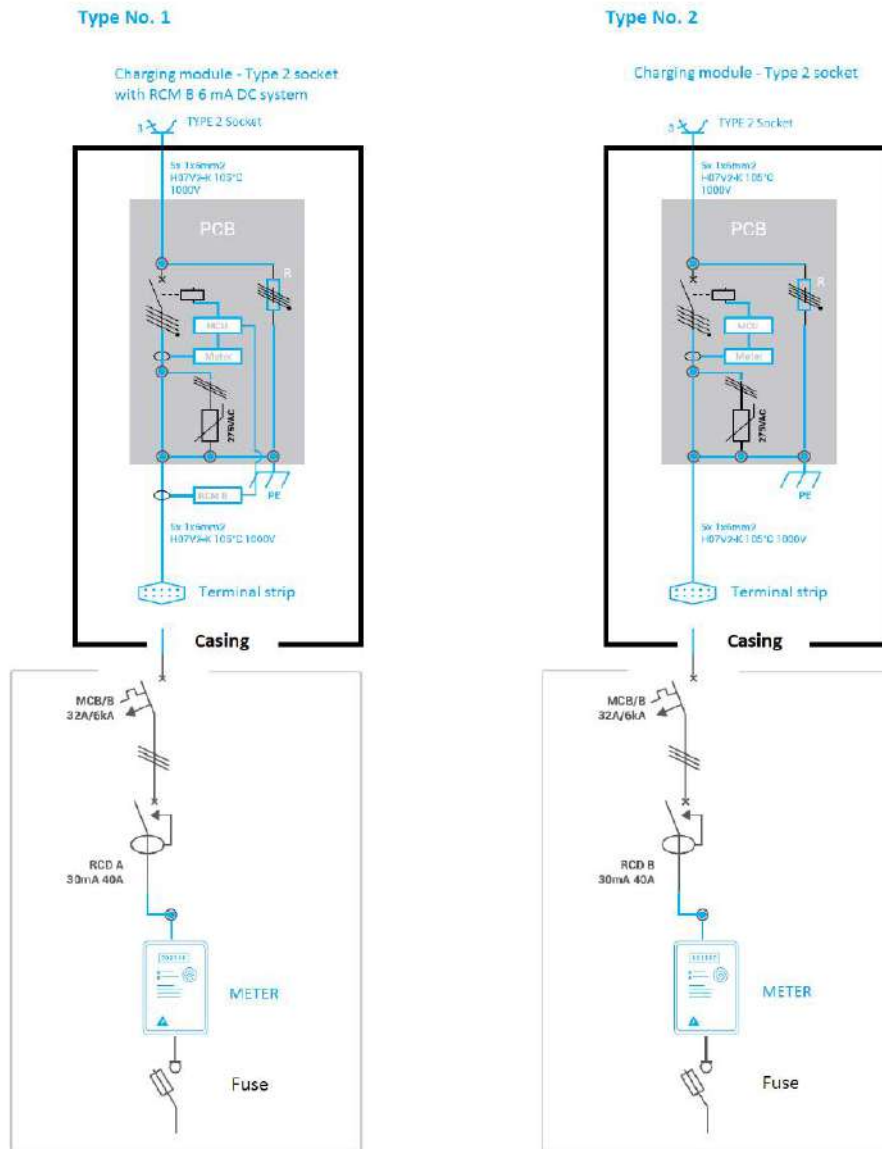

Fig. 19: Diagram of connection variants 1./2.

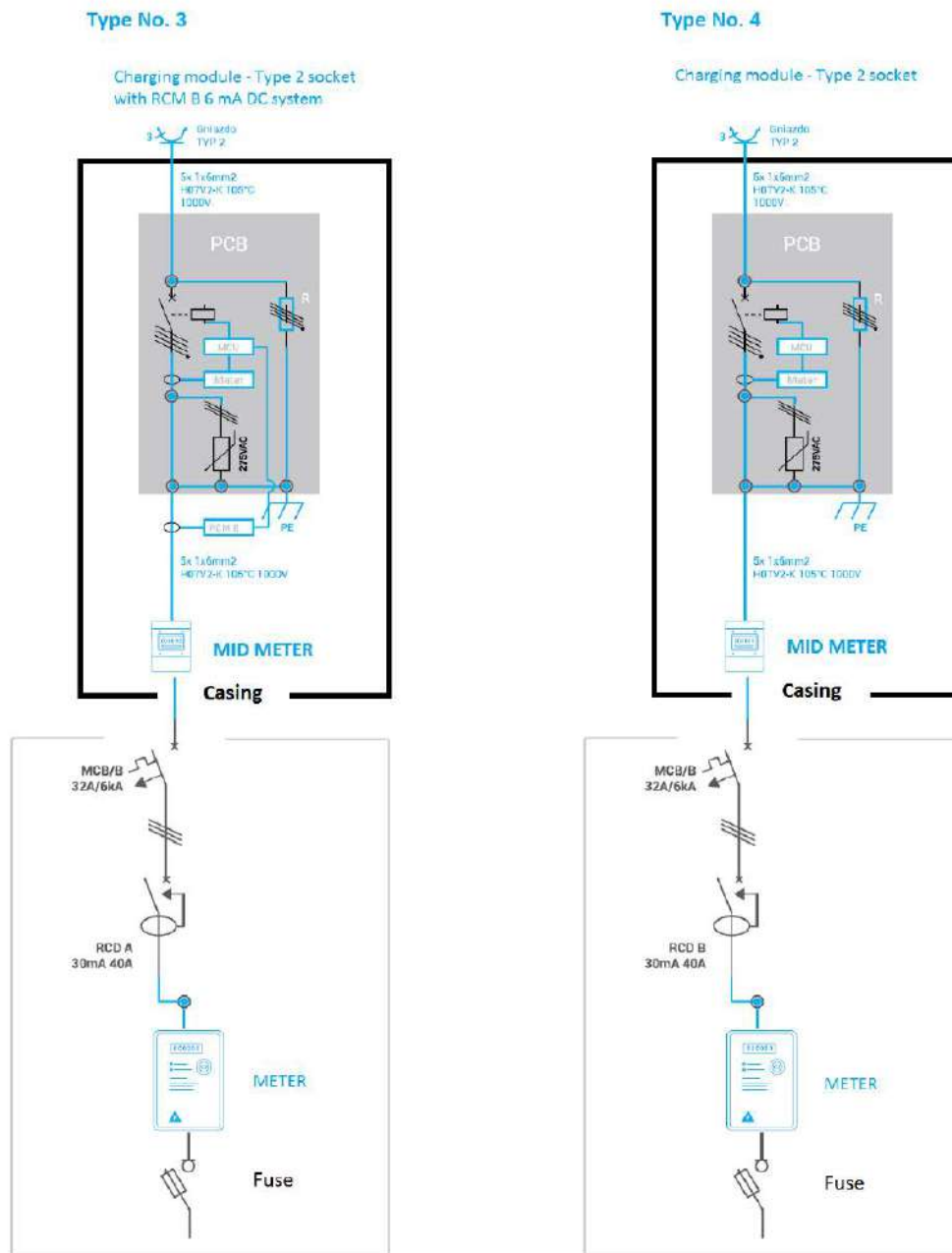

Fig. 20: Diagram of connection variants 2./2.

5.1.1. Standard power connection

1. **Prepare the power supply cable..** Remove 200 mm of the main insulation off the power supply cable. Terminate the individual wires of the cable with fork (M4 or M5 size) or sleeve terminals.
2. Insert the power supply cables into the terminals
3. Use a PZ2 end screwdriver to tighten the terminals with 1,5 N m torque.

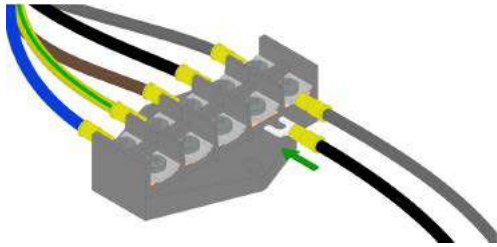

Fig. 21: Connection using fork terminals.

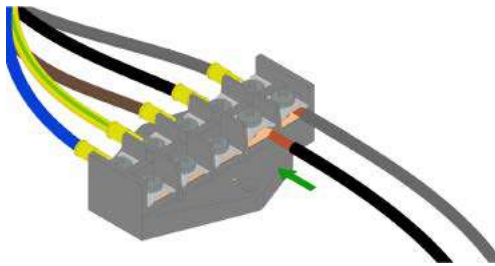

Fig. 22: Connection with solid conductors-wire



Fig. 23: Electrical connection executed correctly.

HINT

The colors of the phase wires in the ENELION WALLBOX may not correspond to the colors of the power supply wires while following the guidelines on the ENELION WALLBOX label. This is a normal and expected situation when using the phase rotation feature.

5.1.2. Power connection in version with MID meter

- 1. Prepare the power cord.** Remove 200 mm of the main insulation off the power supply cable. Terminate the individual wires of the cable with sleeve terminals..
- 2. Insert the power cables into the terminals of the MID meter and tighten them.** Unless otherwise marked on the label of the device, make a standard connection in accordance with the markings on the meter. The PE protective conductor should be connected to the pre-pared coupling.

MID meter communication connection should be done according to the diagram below:

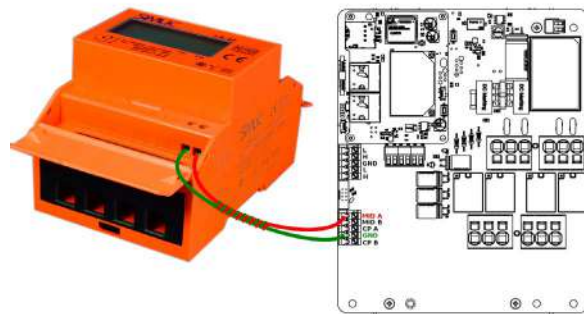

Fig. 24: MID meter communication connection.

INFO

It is also possible to use a three-wire power supply in a TN-S network. The possible connection methods for the device are described in the User Manual in the section titled Device Configuration..

HINT

The colors of the phase wires in ENELION Box may not match the colors of the power cables, maintaining, however, the guidelines on ENELION WALLBOX label. This is a correct and expected situation when using the phase sequence function.

5.1.3. RCMB Connection

ENELION RCM B – Residual Current Monitor typeB-accessory. ENELION RCM B in combination with the RCD A used in the switchgear meet all safety requirements.

1. Connect the device to the dedicated socket on the PilotBox board. [Fig. 25]

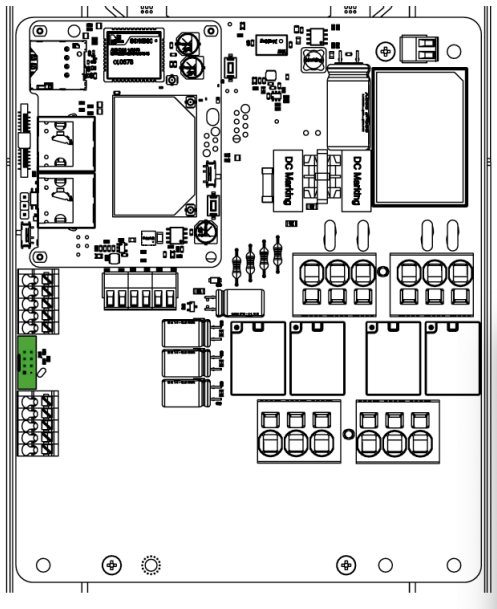

Fig. 25: PilotBox RCMB socket.

2. Pass through the RCMB hole four powering cables (All three phases and neutral cord.)

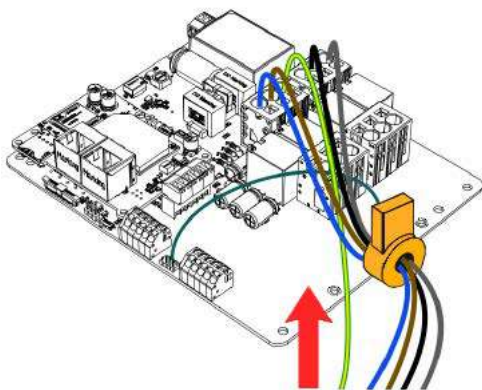

Fig. 26: RCM B connection

HINT

The way of cables through the RCMB hole does not matter. The RCMB monitor could be freely assembled on the socket cables or on the main income cables.

INFO

More information in the User Manual.

5.2. ENELION Chain

The ENELION Chain network is based on a serial, wired CAN bus. For installation, it is recommended to use a CAT5e or better network cable with copper wires, not CCA (Copper Clad Aluminium). Communication utilizes a single twisted pair of wires along with the cable shield.

Select one pair of wires (color) and consistently use it throughout the entire installation. The shield wire should be connected only at one end of each network segment, as shown in the sample diagram.

Depending on the device, the connection to the ENELION Chain network is made in various ways.

Prepare communication cables

1. (a) For devices at the beginning of the network, select a pair of communication cables.
2. (b) For devices along the network, prepare the cables entering the device by connecting the wires from the incoming and outgoing cables (for Variant A) or passing them to the next point (for Variant B, see diagrams below).

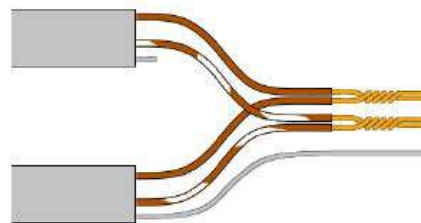

Fig. 27: Incoming and outgoing communication cable connection (variant A)

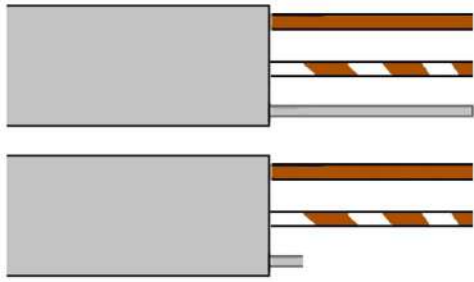

Fig. 28: Incoming and outgoing communication cables (variant B)

3. Release the connector terminal using a flathead screwdriver and place the wires in the appropriate slots. For devices at the beginning and end of the network, single wires will be used.

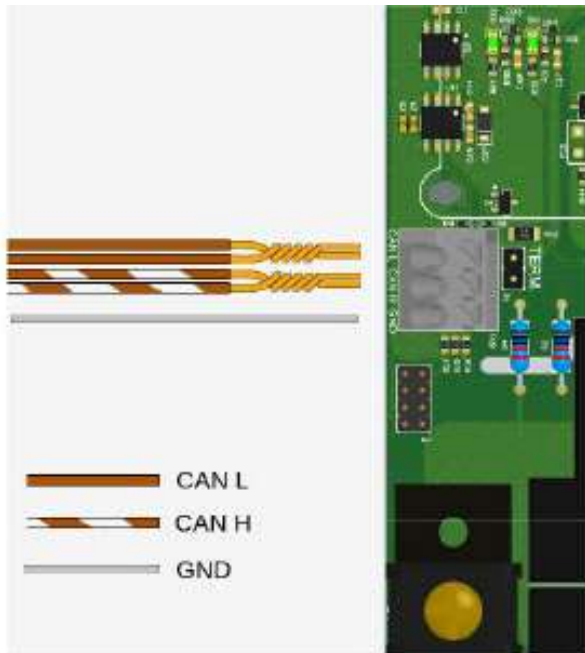

Fig. 29: Diagram of ENELION Chain communication cables connection (variant A)

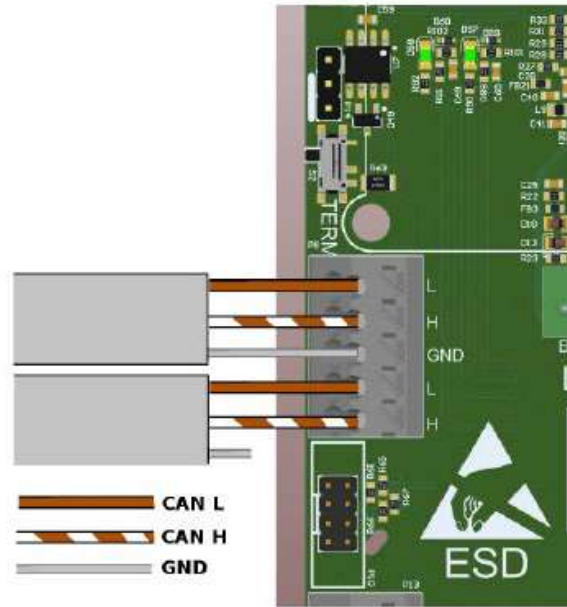

Fig. 30: Diagram of ENELION Chain communication cables connection (variant B)

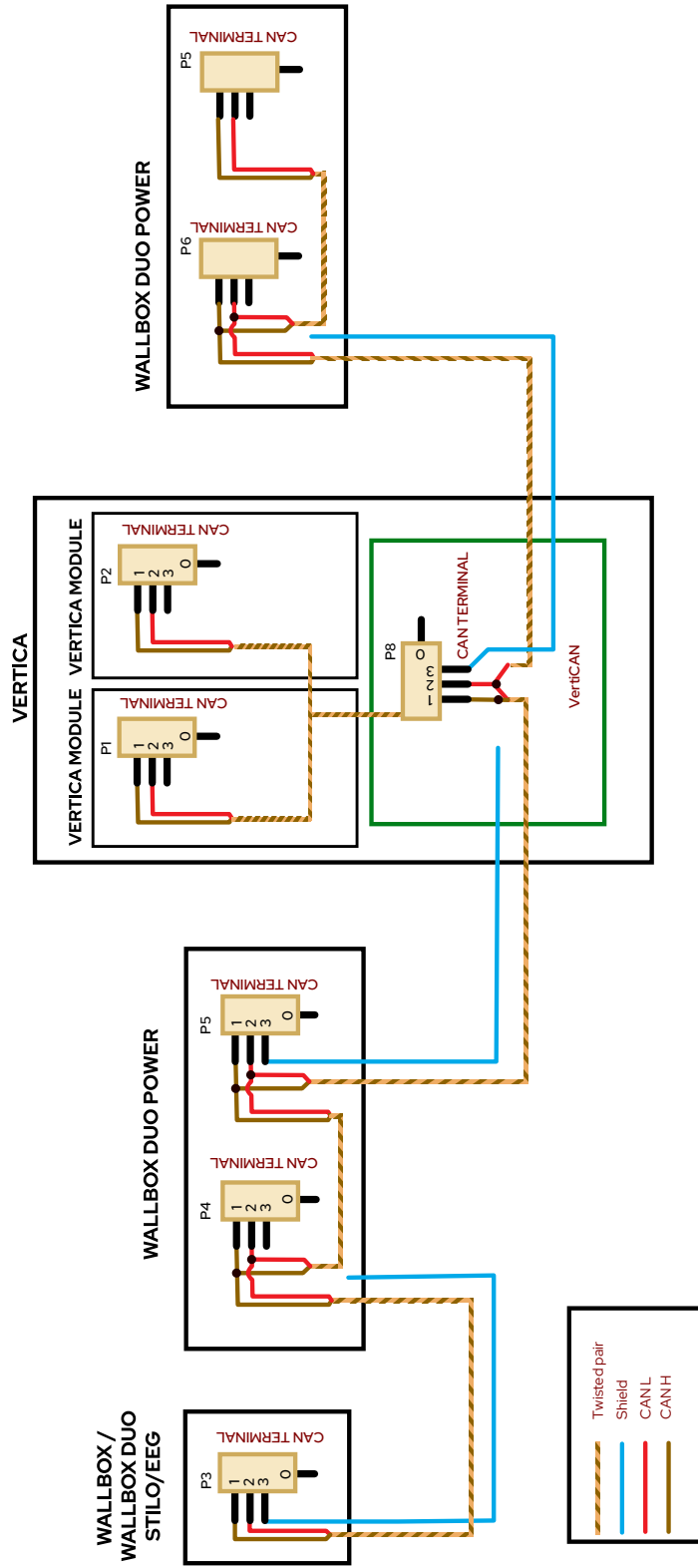

Fig. 31: „The ends of the bus must be terminated with a 120 Ohm resistor, to do this, enable termination on the PCBs of devices at the network's edge.

- For devices at the beginning and end of the network, apply termination. For Variant A, termination is achieved by placing a jumper on the pins as shown in the attached diagram [Fig. 32]. In the case of Variant B, termination is done by toggling the slide switch downward, showing a white square. In an alternative version, if there is no switch, you should toggle the jumper to connect the two lower pins on the 3-pin strip, where the white line is [Fig. 33].

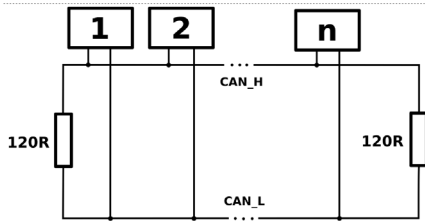

Fig. 32: Termination diagram.



Fig. 33: A sample jumper.

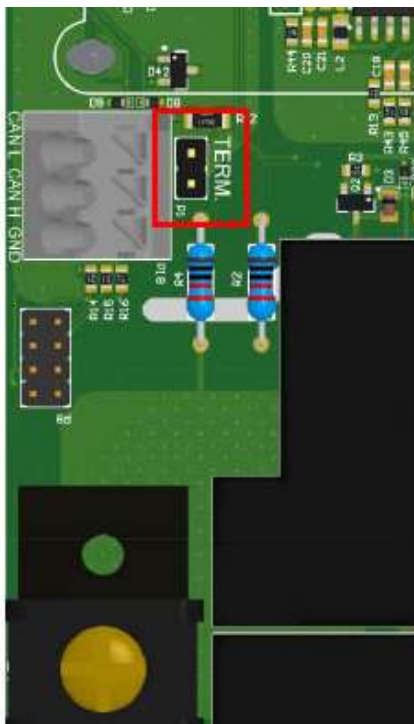

Fig. 34: The place of applying the terminating jumper (variant A)

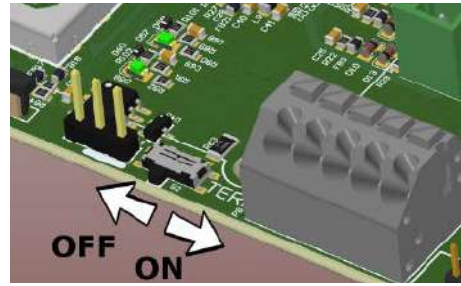

Fig. 35: The place of applying the terminating jumper (variant B)

Please note that in the case of a single WALLBOX DUO POWER device, a short CAN network is created. In this situation, termination is required on at least one WDP board.

5.3. Internet connections via Ethernet interface in LAN network

To provide the Internet connection to a charger equipped with ENELION Bridge module via Ethernet interface:

- Insert the Ethernet cable into the device through the gland for communication cables.
- Terminate the cable with the RJ45 connector according to TIA-568A/B to 100BaseT..

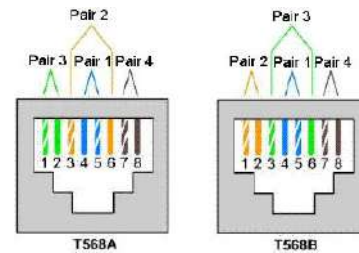

Fig. 36: Termination of the Ethernet cable according to TIA-568A/B to 100BaseT.

- Connect the Ethernet cable to the WAN/INTERNET socket of ENELION Bridge module marked with number 2.

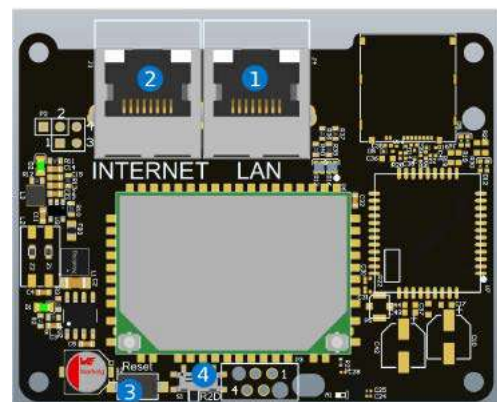

Fig. 37: ENELION Bridge module diagram..

6. Maintenance

The manufacturer recommends conducting a device inspection once every 12 months for safety and maintenance reasons. The inspection is not mandatory.

The device is designed to operate in temperatures from -25°C to 55°C. The manufacturer does not guarantee the proper functioning of the charging station in temperatures outside the specified range. Chargers that are damaged because of exposure to temperatures below -25°C or above 55°C are not covered under the warranty.

In case it is necessary to open the device, make sure that it is disconnected from the power source. With the device installed outdoors, make sure that there is no precipitation or strong wind.

ⓘ WARNING

The device may only be opened by a qualified and authorized person.

6.1. Cleaning

The correct way to clean the charger is to wipe the housing with a microfiber cloth using a cleaning agent dedicated to anodized aluminum. Plexiglas elements (front panel) and plastic elements (socket) should be cleaned with a microfiber cloth using a cleaning agent dedicated to cleaning windowpanes. Other cleaning methods (e.g. wire brush) may lead to the damage of the device housing. Damage resulting from improper cleaning of the device does not constitute grounds for warranty claims.

ⓘ WARNING

The device meets the IP54 standard. Therefore, it is forbidden to wash the charger with pressure washers, garden hoses, shower or any other water stream sources.

6.2. Repair

The manufacturer allows for the repair of public, publicly accessible charging stations without the need for re-inspection by the Office of Technical Inspection (UDT).

The manufacturer permits modular repairs, i.e., the replacement of the entire module or device instead of repairing individual components.

7. Technical data

7.1. ENELION WALLBOX

Electrical data	
Routing of the power cord Surface mounted	Surface mounted
Power cord cross-section	Recommended minimum cross-section) 5 x 6,0 mm ² (32 A nominal current)
Supply voltage (Europe)	3 x230 V/400 VAC (+-10%)
Voltage frequency	50 Hz/60 Hz
Network type	TN, TT (IT per special request)
Protection Class	Class I

Mechanical data	
Dimensions (width x height x depth)	271 mmx 249 mm x 144 mm
Weight	3,1 kg ~ 5%
IP class	IP54
Mechanical strength class	IK10

Interface	
Charging network development	ENELION Chain
Adds-oni	<ul style="list-style-type: none"> • ENELION MID • ENELION ENELION VERTICA Splitter • RCDB
RFID	MIFARE cards compliant with ISO 14443

Ambient conditions	
Working temperature	from 25°C to 55°C
Storage temperature range	from 40°C to 80°C
Permitted relative air humidity	from 5% to 95%
Elevation above the sea level	maximum 2000 m

Signs of installation faults	
Damaged varistors on PilotBox	It means faulty connection powering cords

WARNING

Above information may be the basis for exclusion of warranty.

